

RF12B programming guide

1. Brief description

RF12B is a low cost FSK transceiver IC with integrated all RF functions in a single chip. It only need a MCU, a crystal, a decouple capacitor and antenna to build a hi reliable FSK transceiver system. The operation frequency can cover 400 to 1000MHz.

RF12B supports a command interface to setup frequency, deviation, output power and also data rate. No need any hardware adjustment when using in frequency-hopping applications

RF12B can be used in applications such as remote control toys, wireless alarm, wireless sensor, wireless keyboard/mouse, home-automation and wireless data collection.

2. Commands

1. Timing diagram

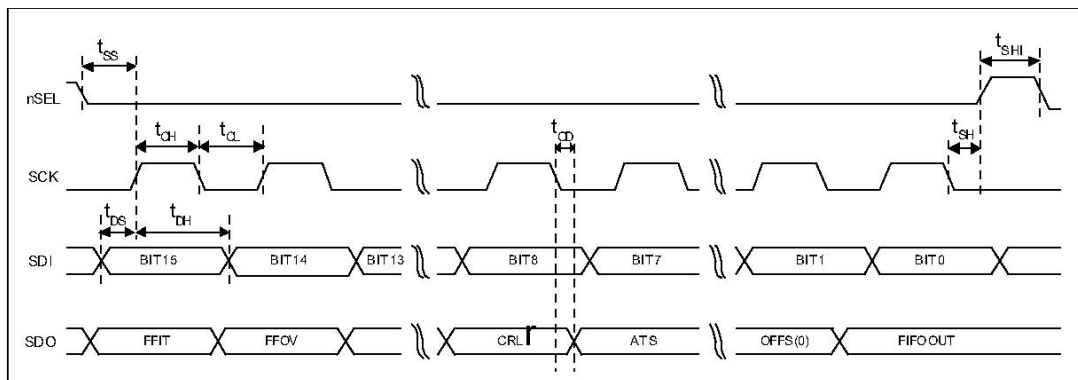

2. Configuration Setting Command

bit	15	14	13	12	11	10	9	8	7	6	5	4	3	2	1	0	POR
	1	0	0	0	0	0	0	0	e1	ef	b1	b0	x3	x2	x1	x0	8008h

e 1: Enable TX register

e f: Enable RX FIFO buffer

b1..b0: select band

b1	b0	band[MHz]
0	0	Reserved
0	1	433
1	0	868
1	1	915

x3..x0: select crystal load capacitor

x3	x2	x1	x0	load capacitor [pF]
0	0	0	0	8.5
0	0	0	1	9.0
0	0	1	0	9.5
0	0	1	1	10.0
.....			
1	1	1	0	15.5
1	1	1	1	16.0

3. Power Management Command

bit	15	14	13	12	11	10	9	8	7	6	5	4	3	2	1	0	POR
	1	0	0	0	0	0	1	0	er	ebb	et	es	ex	eb	ew	dc	8208h

- er: Enable receiver
- ebb: Enable base band block
- et: Enable transmitter
- es: Enable synthesizer
- ex: Enable crystal oscillator
- eb: Enable low battery detector
- ew: Enable wake-up timer
- dc: Disable clock output of CLK pin

4. Frequency Setting Command

bit	15	14	13	12	11	10	9	8	7	6	5	4	3	2	1	0	POR
	1	0	1	0	f11	f10	f9	f8	f7	f6	f5	f4	f3	f2	f1	f0	A680h

f11..f0: Set operation frequency:

433band: $F_c = 430 + F * 0.0025$ MHz

868band: $F_c = 860 + F * 0.0050$ MHz

915band: $F_c = 900 + F * 0.0075$ MHz

F_c is carrier frequency and F is the frequency parameter. $36 \leq F \leq 3903$

5. Data Rate Command

bit	15	14	13	12	11	10	9	8	7	6	5	4	3	2	1	0	POR
	1	1	0	0	1	0	0	0	cs	r6	r5	r4	r3	r2	r1	r0	C623h

r6..r0: Set data rate:

$$BR=10000000/29/ (R+1) / (1+cs*7)$$

6. Receiver Control Command

bit	15	14	13	12	11	10	9	8	7	6	5	4	3	2	1	0	POR
	1	1	0	0	0	P16	d1	d0	i2	i1	i0	g1	g0	r2	r1	r0	9080h

P16: select function of pin16

P16	
0	Interrupt input
1	VDI output

i2..i0:select baseband bandwidth

i2	i1	i0	Baseband Bandwidth [kHz]
0	0	0	reserved
0	0	1	400
0	1	0	340
0	1	1	270
1	0	0	200
1	0	1	134
1	1	0	67
1	1	1	reserved

d1..d0: select VDI response time

d1	d0	Response
0	0	Fast
0	1	Medium
1	0	Slow
1	1	Always on

g1..g0: select LNA gain

g1	g0	LNA gain (dBm)
0	0	0
0	1	-6
1	0	-14
1	1	-20

r2..r0: select DRSSI threshold

r2	r1	r0	RSSIseth [dBm]
0	0	0	-103
0	0	1	-97
0	1	0	-91
0	1	1	-85
1	0	0	-79
1	0	1	-73
1	1	0	Reserved
1	0	1	Reserved

The actual DRSSI threshold is related to LNA setup:

$$RSSI_{th} = RSSI_{seth} + G_{LNA}$$

7. Data Filter Command

bit	15	14	13	12	11	10	9	8	7	6	5	4	3	2	1	0	POR
	1	1	0	0	0	0	1	0	al	ml	1	s	1	f2	f1	f0	C22Ch

al: Enable clock recovery auto-lock

ml: Enable clock recovery fast mode

s: select data filter type

s	Filter type
0	Digital filter
1	Analog RC filter

f1..f0: Set DQD threshold

8. FIFO and Reset Mode Command

bit	15	14	13	12	11	10	9	8	7	6	5	4	3	2	1	0	POR
	1	1	0	0	1	0	1	0	f3	f2	f1	f0	sp	al	ff	dr	CA80h

f3..f0: Set FIFO interrupt level

sp: Select the length of the synchron pattern:

sp	Byte1	Byte0 (POR)	Synchron Pattern (Byte1+Byte0)
0	2Dh	D4h	2DD4h
1	Not used	D4h	D4h

al: select FIFO fill start condition

al	condition
0	Sync-word
1	Always

ff: Enable FIFO fill

dr: Disable hi sensitivity reset mode

9. Synchron pattern Command

bit	15	14	13	12	11	10	9	8	7	6	5	4	3	2	1	0	POR
	1	1	0	0	1	1	1	0	b7	b6	b5	b4	b3	b2	b1	b0	CED4h

This command is used to reprogram the synchronic pattern;

10. Receiver FIFO Read Command

bit	15	14	13	12	11	10	9	8	7	6	5	4	3	2	1	0	POR
	1	0	1	1	0	0	0	0	0	0	0	0	0	0	0	0	B00h

This command is used to read FIFO data when FFIT interrupt generated. FIFO data output starts at 8th SCK period.

11. AFC Command

bit	15	14	13	12	11	10	9	8	7	6	5	4	3	2	1	0	POR
	1	1	0	0	0	1	0	0	a1	a0	r1	r0	st	fi	oe	en	C4F7h

a1..a0: select AFC auto-mode:

a1	a0	
0	0	Controlled by MCU
0	1	Run once at power on
1	0	Keep offset when VDI hi
1	1	Keeps independently from VDI

r1..r0: select range limit

r1	r0	range (fres)
0	0	No restriction
0	1	+15/-16
1	0	+7/-8
1	1	+3-4

fres

315, 433band: 2.5kHz

868band: 5kHz

915band: 7.5kHz

st: st goes hi will store offset into output register

fi: Enable AFC hi accuracy mode

oe: Enable AFC output register

en: Enable AFC function

12. TX Configuration Control Command

bit	15	14	13	12	11	10	9	8	7	6	5	4	3	2	1	0	POR
	1	0	0	1	1	0	0	mp	m3	m2	m1	m0	0	p2	p1	p0	9800h

m: select modulation polarity

m2..m0: select frequency deviation:

m3	m2	m1	m0	frequency deviation [kHz]
0	0	0	0	15
0	0	0	1	30
0	0	1	0	45
0	0	1	1	60
0	1	0	0	75
0	1	0	1	90
0	1	1	0	105
0	1	1	1	120
1	0	0	0	135
1	0	0	1	150
1	0	1	0	165
1	0	1	1	180
1	1	0	0	195
1	1	0	1	210
1	1	1	0	225
1	1	1	1	240

p2..p0: select output power

p2	p1	p0	Output power[dBm]
0	0	0	0
0	0	1	-3
0	1	0	-6
0	1	1	-9
1	0	0	-12
1	0	1	-15
1	1	0	-18
1	0	1	-21

13. PLL Setting Command

bit	15	14	13	12	11	10	9	8	7	6	5	4	3	2	1	0	POR
	1	1	0	0	1	1	0	0	0	ob1	ob0	1	ddy	ddit	1	bw0	CC77h

ob1-ob0: Microcontroller output clock buffer rise and fall time control.

ob1	ob0	Selected uC CLK frequency
0	0	5 or 10 MHz (recommended)
0	1	3.3 MHz
1	X	2.5 MHz or less

ddy: phase detector delay enable.

ddi: disables the dithering in the PLL loop.

bw1-bw0: select PLL bandwidth

bw0	Max bit rate [kbps]	Phase noise at 1MHz offset [dBc/Hz]
0	86.2	-107
1	256	-102

14. Transmitter Register Write Command

bit	15	14	13	12	11	10	9	8	7	6	5	4	3	2	1	0	POR
	1	0	1	1	1	0	0	0	t7	t6	t5	t4	t3	t2	t1	t0	B8AAh

This command is use to write a data byte to RF12 and then RF12 transmit it

15. Wake-Up Timer Command

bit	15	14	13	12	11	10	9	8	7	6	5	4	3	2	1	0	POR
	1	1	1	r4	r3	r2	r1	r0	m7	m6	m5	m4	m3	m2	m1	m0	E196h

The wake-up period is determined by:

$$T_{\text{wake-up}} = M * 2^R \text{ [ms]}$$

For continual operation, bit 'et' must be cleared and set

16. Low Duty-Cycle Command

bit	15	14	13	12	11	10	9	8	7	6	5	4	3	2	1	0	POR
	1	1	0	0	1	0	0	0	d6	d5	d4	d3	d2	d1	d0	en	C80Eh

d6..d0: Set duty cycle

$$D. C. = (D * 2 + 1) / M * 100\%$$

en: Enable low duty cycle mode

17. Low Battery Detector and Microcontroller Clock Divider Command

bit	15	14	13	12	11	10	9	8	7	6	5	4	3	2	1	0	POR
	1	1	0	0	0	0	0	0	d2	d1	d0	0	v3	v2	v1	v0	C000h

d2..d0: select frequency of CLK pin

d2	d1	d0	Clock frequency[MHz]
0	0	0	1
0	0	1	1.25
0	1	0	1.66
0	1	1	2
1	0	0	2.5
1	0	1	3.33
1	1	0	5
1	1	1	10

CLK signal is derive form crystal oscillator and it can be applied to MCU clock in to save a second crystal.

If not used, please set bit “dc” to disable CLK output

To integrate the load capacitor internal can not only save cost, but also adjust reference frequency by software

v3..v0: Set threshold voltage of Low battery detector:

$$V_{lb} = 2.2 + V * 0.1 \text{ [V]}$$

18. Status Read Command

bit	15	14	13	12	11	10	9	8	7	6	5	4	3	2	1	0	POR
	0	x	x	x	x	x	x	x	x	x	x	x	x	x	x	x	-

This command starts with a 0 and be used to read internal status register

3. Demo flow diagram

Transmitter:

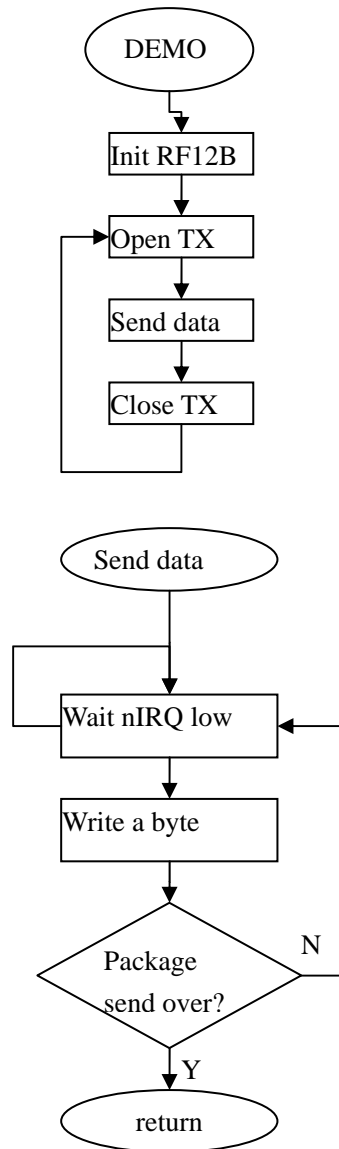

Note: Initialize RF12B and open transmitter, RF12B will transmit a byte and pull nIRQ low when transmit over, then MCU can write next byte to transmit

Receiver:

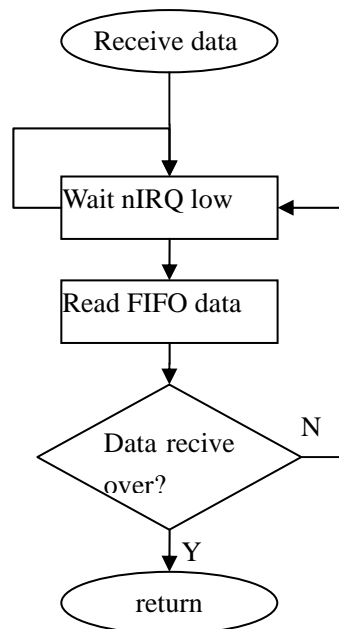
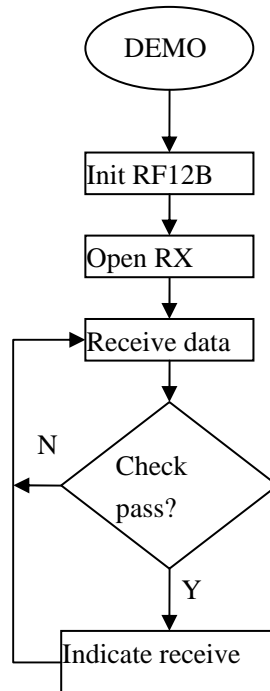

Note: After RF12B initialization, Open FIFO receive mode and wait nIRQ low, only then MCU can read received and stored in FIFO data. For next package receive, please reset FIFO.

4. Example 1 (for AVR microcontroller)

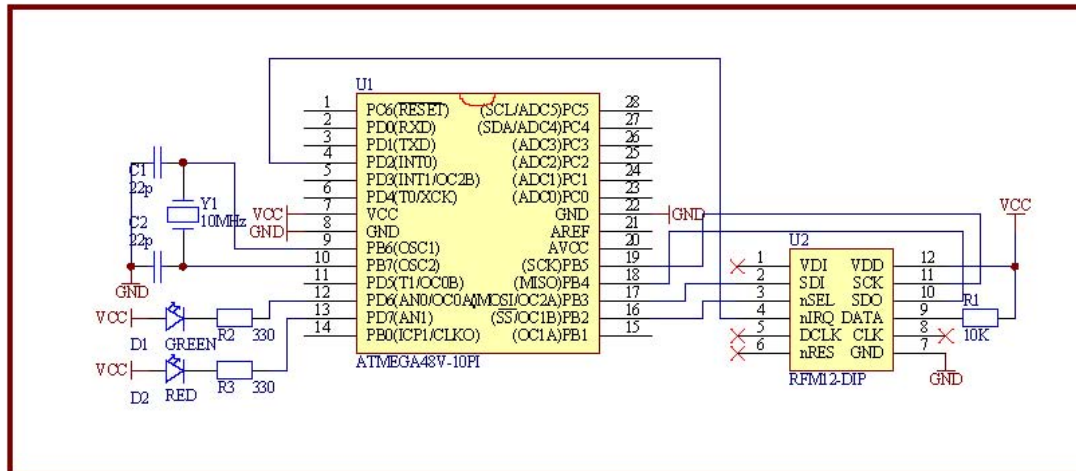

RF12 transmitter demo:

/*

```

; copyright (c) 2006
;Title           RF12 TX simple example based on AVR C
;Company:        Hope microelectronic Co.,Ltd.
;Author:         Tank
;Current version: v1.0
;Date:           2006-11-13
;processor       ATMEGA48
;Clock:          10MHz Crystal
;Contact:        +86-0755-86106557
;E-MAIL:         hopefsk@hoperf.com
    
```

Connections

ATMEGA48 SIDE	RF12 SIDE
SCK----->	SCK
MISO----->	SDO
MOSI----->	SDI
SS----->	nSEL
INT0<-----	nIRQ

PD6: LED GREEN

PD7: LED RED

*/

```
#include <mega48.h>

#define DDR_IN          0
#define DDR_OUT        1

#define PORT_SEL        PORTB
#define PIN_SEL         PINB
#define DDR_SEL         DDRB

#define PORT_SDI        PORTB
#define PIN_SDI         PINB
#define DDR_SDI         DDRB

#define PORT_SCK        PORTB
#define PIN_SCK         PINB
#define DDR_SCK         DDRB

#define PORT_SDO        PORTB
#define PIN_SDO         PINB
#define DDR_SDO         DDRB

#define PORT_DATA       PORTD
#define PIN_DATA        PIND
#define DDR_DATA        DDRD

#define PB7              7//--\
#define PB6              6// |
#define RFXX_SCK         5// |
#define RFXX_SDO         4// |RF_PORT
#define RFXX_SDI         3// |
#define RFXX_SEL         2// |
#define NC               1// |
#define PB0              0//--/

#define SEL_OUTPUT()    DDR_SEL |= (1<<RFXX_SEL)
#define HI_SEL()        PORT_SEL|= (1<<RFXX_SEL)
#define LOW_SEL()       PORT_SEL&=~(1<<RFXX_SEL)

#define SDI_OUTPUT()    DDR_SDI |= (1<<RFXX_SDI)
#define HI_SDI()        PORT_SDI|= (1<<RFXX_SDI)
#define LOW_SDI()       PORT_SDI&=~(1<<RFXX_SDI)

#define SDO_INPUT()     DDR_SDO&= ~(1<<RFXX_SDO)
```

```
#define SDO_HI()          PIN_SDO&(1<<RFXX_SDO)

#define SCK_OUTPUT()     DDR_SCK |= (1<<RFXX_SCK)
#define HI_SCK()         PORT_SCK|= (1<<RFXX_SCK)
#define LOW_SCK()        PORT_SCK&=~(1<<RFXX_SCK)

#define RF12_DATA        4//PD4
#define DATA_OUT        DDR_DATA|=1<<RF12_DATA
#define HI_DATA          PORT_DATA|=1<<RF12_DATA

#define LEDG_OUTPUT()    DDRD|=~(1<<6)
#define LEDR_OUTPUT()    DDRD|=~(1<<7)

#define LEDG_ON()        PORTD&=~(1<<6)
#define LEDG_OFF()       PORTD|=~(1<<6)
#define LEDR_ON()        PORTD&=~(1<<7)
#define LEDR_OFF()       PORTD|=~(1<<7)
```

```
void RFXX_PORT_INIT(void) {
    HI_SEL();
    HI_SDI();
    LOW_SCK();
    SEL_OUTPUT();
    SDI_OUTPUT();
    SDO_INPUT();
    SCK_OUTPUT();
}

unsigned int RFXX_WRT_CMD(unsigned int aCmd) {
    unsigned char i;
    unsigned int temp;
    LOW_SCK();
    LOW_SEL();
    for(i=0;i<16;i++) {
        temp<<=1;
        if(SDO_HI()) {
            temp|=0x0001;
        }
        LOW_SCK();
        if(aCmd&0x8000) {
            HI_SDI();
        }else{
            LOW_SDI();
        }
    }
}
```

```
    HI_SCK();
    aCmd<<=1;
};
LOW_SCK();
HI_SEL();
return(temp);
}
void RF12_INIT(void) {
    RFXX_WRT_CMD(0x80D7); //EL, EF, 433band, 12. 0pF
    RFXX_WRT_CMD(0x8239); //!er, !ebb, ET, ES, EX, !eb, !ew, DC
    RFXX_WRT_CMD(0xA640); //A140=430. 8MHz
    RFXX_WRT_CMD(0xC647); //4. 8kbps
    RFXX_WRT_CMD(0x94A0); //VDI, FAST, 134kHz, 0dBm, -103dBm
    RFXX_WRT_CMD(0xC2AC); //AL, !m1, DIG, DQD4
    RFXX_WRT_CMD(0xCA81); //FIFO8, SYNC, !ff, DR
    RFXX_WRT_CMD(0xCED4); //SYNC=2DD4;
    RFXX_WRT_CMD(0xC483); //@PWR, NO RSTRIC, !st, !fi, OE, EN
    RFXX_WRT_CMD(0x9850); //!mp, 9810=30kHz, MAX OUT
    RFXX_WRT_CMD(0xCC77); //OB1, OBO, ! lpx, ! ddy, DDIT, BW0
    RFXX_WRT_CMD(0xE000); //NOT USE
    RFXX_WRT_CMD(0xC800); //NOT USE
    RFXX_WRT_CMD(0xC040); //1. 66MHz, 2. 2V
}
void RF12_SEND(unsigned char aByte) {
    while(PIND&(1<<2)); //wait for previously TX over
    RFXX_WRT_CMD(0xB800+aByte);
}

void Delay_ms(unsigned char amS) {
    unsigned char i;
    unsigned int j;
    for(i=0; i<amS; i++) for(j=0; j<914; j++);
}
void main(void)
{
    unsigned int i, j;
    unsigned char ChkSum;

    #asm("cli");
    DDRB=0x00; //PB INPUT;
    DDRD=0x00; //PD INPUT;

    //POWER ON indication: both LEDR and LEDG blink 3 times
    LEDG_OFF();
```

```
LEDR_OFF();
LEDG_OUTPUT();
LEDR_OUTPUT();
for(i=0;i<3;i++){
    Delay_ms(200);
    LEDG_ON();
    LEDR_ON();
    Delay_ms(200);
    LEDG_OFF();
    LEDR_OFF();
}

LEDG_OFF();
LEDR_OFF();

RFXX_PORT_INIT();

RF12_INIT();

DDRD|=(1<<RF12_DATA);
PORTD|=(1<<RF12_DATA);// SET nFFS pin HI when using TX register
DDRD&=~(1<<2); //PD2(INT0)

while(1){
    LEDR_ON();
    RFXX_WRT_CMD(0x0000);//read status register
    RFXX_WRT_CMD(0x8239);//!er, !ebb, ET, ES, EX, !eb, !ew, DC

    ChkSum=0;
    RF12_SEND(0xAA);//PREAMBLE
    RF12_SEND(0xAA);//PREAMBLE
    RF12_SEND(0xAA);//PREAMBLE
    RF12_SEND(0x2D);//SYNC HI BYTE
    RF12_SEND(0xD4);//SYNC LOW BYTE
    RF12_SEND(0x30);//DATA BYTE 0
    ChkSum+=0x30;
    RF12_SEND(0x31);//DATA BYTE 1
    ChkSum+=0x31;
    RF12_SEND(0x32);
    ChkSum+=0x32;
    RF12_SEND(0x33);
    ChkSum+=0x33;
    RF12_SEND(0x34);
```

```
    ChkSum+=0x34;
    RF12_SEND(0x35);
    ChkSum+=0x35;
    RF12_SEND(0x36);
    ChkSum+=0x36;
    RF12_SEND(0x37);
    ChkSum+=0x37;
    RF12_SEND(0x38);
    ChkSum+=0x38;
    RF12_SEND(0x39);
    ChkSum+=0x39;
    RF12_SEND(0x3A);
    ChkSum+=0x3A;
    RF12_SEND(0x3B);
    ChkSum+=0x3B;
    RF12_SEND(0x3C);
    ChkSum+=0x3C;
    RF12_SEND(0x3D);
    ChkSum+=0x3D;
    RF12_SEND(0x3E);
    ChkSum+=0x3E;
    RF12_SEND(0x3F);    //DATA BYTE 15
    ChkSum+=0x3F;
    RF12_SEND(ChkSum); //send chek sum
    RF12_SEND(0xAA); //DUMMY BYTE
    RF12_SEND(0xAA); //DUMMY BYTE
    RF12_SEND(0xAA); //DUMMY BYTE

    RFXX_WRT_CMD(0x8201);
    LEDR_OFF();
    LEDG_OFF();
    for(i=0;i<10000;i++) for(j=0;j<123;j++); //sleep 1 second appr.

};
}
```

RF12 receiver demo

/*

```
    ; copyright (c) 2006
    ;Title           RF12 RX simple example based on AVR C
    ;Company:       Hope microelectronic Co.,Ltd.
    ;Author:        Tank
```



```
;Current version: v1.0
;Date: 2006-11-17
;processor ATMEGA48
;Clock: 10MHz Crystal
;Contact: +86-0755-86106557
;E-MAIL: hopefsk@hoperf.com
```

Connections

```
ATMEGA48 SIDE      RF12 SIDE
SCK----->SCK
MISO<-----SDO
MOSI----->SDI
SS----->nSEL
PD4----->FSK/DATA
INT0<-----nIRQ
```

PD6: LED GREEN

PD7: LED RED

*/

```
#include <mega48.h>
```

```
#define DDR_IN      0
```

```
#define DDR_OUT     1
```

```
#define PORT_SEL    PORTB
```

```
#define PIN_SEL     PINB
```

```
#define DDR_SEL     DDRB
```

```
#define PORT_SDI    PORTB
```

```
#define PIN_SDI     PINB
```

```
#define DDR_SDI     DDRB
```

```
#define PORT_SCK    PORTB
```

```
#define PIN_SCK     PINB
```

```
#define DDR_SCK     DDRB
```

```
#define PORT_SDO    PORTB
```

```
#define PIN_SDO     PINB
```

```
#define DDR_SDO     DDRB
```

```
#define PORT_IRQ      PORTD
#define PIN_IRQ       PIN_D
#define DDR_IRQ       DDRD

#define PORT_DATA     PORTD
#define PIN_DATA      PIN_D
#define DDR_DATA      DDRD

#define PB7           7/--\
#define PB6           6// |
#define RFXX_SCK      5// |
#define RFXX_SDO      4// |RF_PORT
#define RFXX_SDI      3// |
#define RFXX_SEL      2// |
#define NC             1// |
#define PBO           0/--/

#define SEL_OUTPUT()  DDR_SEL |= (1<<RFXX_SEL)
#define HI_SEL()      PORT_SEL|= (1<<RFXX_SEL)
#define LOW_SEL()     PORT_SEL&=~(1<<RFXX_SEL)

#define SDI_OUTPUT()  DDR_SDI |= (1<<RFXX_SDI)
#define HI_SDI()      PORT_SDI|= (1<<RFXX_SDI)
#define LOW_SDI()     PORT_SDI&=~(1<<RFXX_SDI)

#define SDO_INPUT()   DDR_SDO&= ~(1<<RFXX_SDO)
#define LOW_SDO()     PORT_SDO&= (1<<RFXX_SDO)
#define SDO_HI()      PIN_SDO&(1<<RFXX_SDO)

#define SCK_OUTPUT()  DDR_SCK |= (1<<RFXX_SCK)
#define HI_SCK()      PORT_SCK|= (1<<RFXX_SCK)
#define LOW_SCK()     PORT_SCK&=~(1<<RFXX_SCK)

#define RF12_IRQ      2
#define IRQ_IN()      DDR_IRQ &=~(1<<RF12_IRQ)
#define WAIT_IRQ_LOW() while(PIN_D&(1<<RF12_IRQ))

#define RF12_DATA     4//PD4
#define DATA_OUT()   DDR_DATA|=1<<RF12_DATA
#define HI_DATA()     PORT_DATA|=1<<RF12_DATA

#define LEDG_OUTPUT() DDRD|=~(1<<6)
#define LEDR_OUTPUT() DDRD|=~(1<<7)
```

```
#define LEDG_ON()      PORTD&=~(1<<6)
#define LEDG_OFF()    PORTD|= (1<<6)
#define LEDR_ON()     PORTD&=~(1<<7)
#define LEDR_OFF()    PORTD|= (1<<7)

void RFX_PORT_INIT(void) {
    HI_SEL();
    HI_SDI();
    LOW_SCK();
    //SET nFFS pin HI when using FIFO
    HI_DATA();
    SEL_OUTPUT();
    SDI_OUTPUT();
    SDO_INPUT();
    SCK_OUTPUT();
    IRQ_IN();
    DATA_OUT();
}

unsigned int RFX_WRT_CMD(unsigned int aCmd) {
    unsigned char i;
    unsigned int temp;
    temp=0;
    LOW_SCK();
    LOW_SEL();
    for(i=0;i<16;i++) {
        if(aCmd&0x8000) {
            HI_SDI();
        }else{
            LOW_SDI();
        }
        HI_SCK();
        temp<<=1;
        if(SDO_HI()) {
            temp|=0x0001;
        }
        LOW_SCK();

        aCmd<<=1;
    };
    HI_SEL();
    return(temp);
}
```

```
void RF12_INIT(void) {
    RFXX_WRT_CMD(0x80D7); //EL, EF, 433band, 12. 0pF
    RFXX_WRT_CMD(0x82D9); //!er, !ebb, ET, ES, EX, !eb, !ew, DC
    RFXX_WRT_CMD(0xA640); //A140=430. 8MHz
    RFXX_WRT_CMD(0xC647); //4. 8kbps
    RFXX_WRT_CMD(0x94A0); //VDI, FAST, 134kHz, 0dBm, -103dBm
    RFXX_WRT_CMD(0xC2AC); //AL, !m1, DIG, DQD4
    RFXX_WRT_CMD(0xCA81); //FIFO8, SYNC, !ff, DR
    RFXX_WRT_CMD(0xCED4); //SYNC=2DD4;
    RFXX_WRT_CMD(0xC483); //@PWR, NO RSTRIC, !st, !fi, OE, EN
    RFXX_WRT_CMD(0x9850); //!mp, 9810=30kHz, MAX OUT
    RFXX_WRT_CMD(0xCC77); //OB1, OBO, ! lpx, ! ddy, DDIT, BW0
    RFXX_WRT_CMD(0xE000); //NOT USE
    RFXX_WRT_CMD(0xC800); //NOT USE
    RFXX_WRT_CMD(0xC040); //1. 66MHz, 2. 2V
}

unsigned char RF12_RECV(void) {
    unsigned int FIFO_data;
    WAIT_IRQ_LOW();
    RFXX_WRT_CMD(0x0000);
    FIFO_data=RFXX_WRT_CMD(0xB000);
    return(FIFO_data&0x00FF);
}

void Delay_ms(unsigned char amS) {
    unsigned char i;
    unsigned int j;
    for(i=0; i<amS; i++) for(j=0; j<914; j++);
}

void main(void)
{
    unsigned char i;
    unsigned char ChkSum;

    //POWER ON indication: both LEDR and LEDG blink 3 times

    LEDG_OFF();
    LEDR_OFF();
    LEDG_OUTPUT();
    LEDR_OUTPUT();

    for(i=0; i<3; i++) {
        Delay_ms(200);
        LEDG_ON();
        LEDR_ON();
    }
}
```

```
    Delay_ms(200);
    LEDG_OFF();
    LEDR_OFF();
}

    LEDG_OFF();
    LEDR_OFF();

//Initialize command port
RFXX_PORT_INIT();

//Initialize RF12 chip
RF12_INIT();

//Init FIFO
RFXX_WRT_CMD(0xCA81);

while(1) {
    //Enable FIFO
    RFXX_WRT_CMD(0xCA83);
    ChkSum=0;

    //Receive payload data
    for(i=0;i<16;i++) {
        ChkSum+=RF12_RECV();
    }

    //Receive Check sum
    i=RF12_RECV();

    //Disable FIFO
    RFXX_WRT_CMD(0xCA81);

    //Package check
    if(ChkSum==i) {
        LEDG_ON();
        Delay_ms(200);
        LEDG_OFF();
    }
}
}
```

5. Example 2 (for PIC microcontroller)

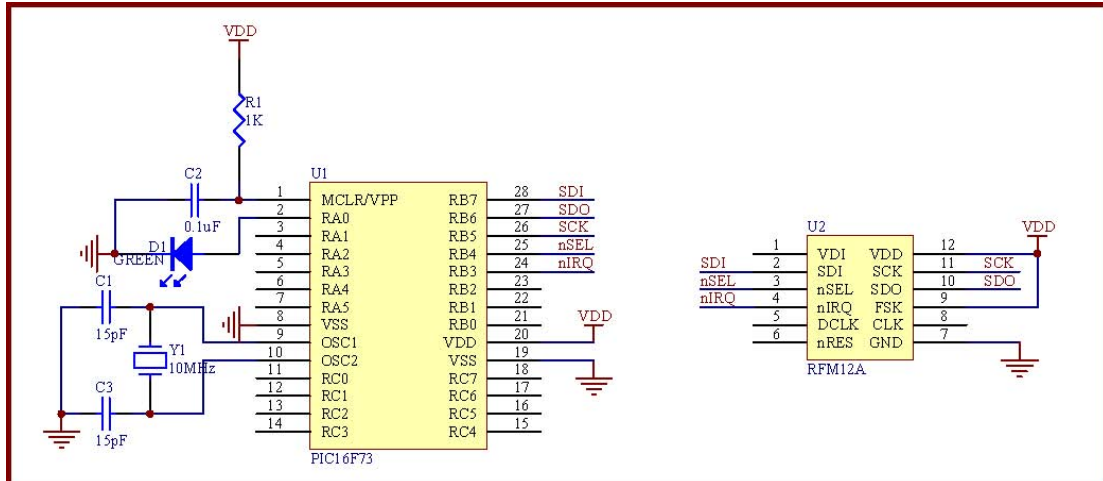

RF12 transmitter demo:

/*

 copyright (c) 2006
 Title: RFM12B transmitter simple example based on PIC C
 Current version: v1.0
 Function: Package send Demo
 Processor PIC16F73 DIP-28
 Clock: 10MHz Crystal
 Operate frequency: 434MHz
 Data rate: 4.8kbps
 Package size: 23byte
 Author: Robben
 Company: Hope microelectronic Co.,Ltd.
 Contact: +86-0755-86106557
 E-MAIL: hopefsk@hoperf.com
 Date: 2006-11-21

 #include "pic.h"
 typedef unsigned char uchar;
 typedef unsigned int uint;
 #define SDI RB7
 #define SDO RB6
 #define SCK RB5
 */

```

  Title: RFM12B transmitter simple example based on PIC C
  Current version: v1.0
  Function: Package send Demo
  Processor PIC16F73 DIP-28
  Clock: 10MHz Crystal
  Operate frequency: 434MHz
  Data rate: 4.8kbps
  Package size: 23byte
  Author: Robben
  Company: Hope microelectronic Co.,Ltd.
  Contact: +86-0755-86106557
  E-MAIL: hopefsk@hoperf.com
  Date: 2006-11-21
  *****
  #include "pic.h"
  typedef unsigned char uchar;
  typedef unsigned int uint;
  #define SDI RB7
  #define SDO RB6
  #define SCK RB5
  */
```

```
#define nSEL          RB4

#define SDI_OUT()    TRISB7=0
#define SDO_IN()    TRISB6=1
#define SCK_OUT()   TRISB5=0
#define nSEL_OUT()  TRISB4=0

void Init_RF12(void);
void Write0( void );
void Write1( void );
void WriteCMD( uint CMD );
void DelayUs( uint us );
void DelayMs( uint ms );
void WriteFSKbyte( uchar DATA );

__CONFIG(0x3FF2);

void Init_RF12(void)
{
    nSEL_OUT();
    SDI_OUT();
    SDO_IN();
    SCK_OUT();
    nSEL=1;
    SDI=1;
    SCK=0;
    WriteCMD(0x80D8); //enable register, 433MHz, 12. 5pF
    WriteCMD(0x8208); //Turn on crystal, !PA
    WriteCMD(0xA640); //
    WriteCMD(0xC647); //
    WriteCMD(0XC677); //
    WriteCMD(0x94A0); //VDI, FAST, 134kHz, 0dBm, -103dBm
    WriteCMD(0xC2AC);
    WriteCMD(0xCA80);
    WriteCMD(0xCA83); //FIFO8, SYNC,
    WriteCMD(0xC49B);
    WriteCMD(0x9850); //!mp, 9810=30kHz, MAX OUT
    WriteCMD(0xE000); //NOT USE
    WriteCMD(0xC80E); //NOT USE
    WriteCMD(0xC000); //1. 0MHz, 2. 2V
}

void main()
{
```

```
uint ChkSum=0;
Init_RF12();
while(1)
{
    WriteCMD(0x8228);    //OPEN PA
    DelayUs( 4 );
    WriteCMD(0x8238);
    NOP();
    NOP();
    WriteFSKbyte( 0xAA );
    WriteFSKbyte( 0xAA );
    WriteFSKbyte( 0xAA );
    WriteFSKbyte( 0x2D );
    WriteFSKbyte( 0xD4 );

    WriteFSKbyte( 0x30 );//DATA0
    ChkSum+=0x30;
    WriteFSKbyte( 0x31 );//DATA1
    ChkSum+=0x31;
    WriteFSKbyte( 0x32 );
    ChkSum+=0x32;
    WriteFSKbyte( 0x33 );
    ChkSum+=0x33;
    WriteFSKbyte( 0x34 );
    ChkSum+=0x34;
    WriteFSKbyte( 0x35 );
    ChkSum+=0x35;
    WriteFSKbyte( 0x36 );
    ChkSum+=0x36;
    WriteFSKbyte( 0x37 );
    ChkSum+=0x37;
    WriteFSKbyte( 0x38 );
    ChkSum+=0x38;
    WriteFSKbyte( 0x39 );
    ChkSum+=0x39;
    WriteFSKbyte( 0x3A );
    ChkSum+=0x3A;
    WriteFSKbyte( 0x3B );
    ChkSum+=0x3B;
    WriteFSKbyte( 0x3C );
    ChkSum+=0x3C;
    WriteFSKbyte(0x3D);
    ChkSum+=0x3D;
    WriteFSKbyte( 0x3E );
```



```
    ChkSum+=0x3E;
    WriteFSKbyte( 0x3F );//DATA15
    ChkSum+=0x3F;
    ChkSum&=0xFF;
    WriteFSKbyte( ChkSum );
    WriteFSKbyte( 0xAA );
    WriteCMD( 0x8208 );      //CLOSE PA
    DelayMs(1000);

}
}
```

```
void Write0( void )
{
    SCK=0;
    NOP();
    SDI=0;
    NOP();
    NOP();
    NOP();
    NOP();
    NOP();
    NOP();
    NOP();
    NOP();
    NOP();
    NOP();
    NOP();
    NOP();
    NOP();
    NOP();
    NOP();
    SCK=1;
    NOP();
}
```

```
void Write1( void )
{
    SCK=0;
    NOP();
    SDI=1;
    NOP();
    NOP();
    NOP();
}
```

```
NOP();
NOP();
NOP();
NOP();
NOP();
NOP();
NOP();
NOP();
NOP();
NOP();
NOP();
NOP();
NOP();
NOP();
SCK=1;
NOP();
}

void WriteCMD( uint CMD )
{
    uchar n=16;
    SCK=0;
    nSEL=0;
    while(n--)
    {
        if(CMD&0x8000)
            Write1();
        else
            Write0();
        CMD=CMD<<1;
    }
    SCK=0;
    nSEL=1;
}

void WriteFSKbyte( uchar DATA )
{
    uchar RGIT=0;
    uint temp=0xB800;
    temp|=DATA;
Loop: SCK=0;
    nSEL=0;
    SDI=0;
    SCK=1;
    if(SD0)                //Polling SD0
```

```
{
  RGIT=1;
}
else
{
  RGIT=0;
}
SCK=0;
SDI=1;
nSEL=1;
if(RGIT==0)
{
  goto Loop;
}
else
{
  RGIT=0;
  WriteCMD(temp);
}
}
```

```
void DelayUs( uint us )
{
  uint i;
  while( us-- )
  {
    i=2;
    while( i-- )
    {
      NOP();
    }
  }
}
```

```
void DelayMs(uint ms)
{
  uchar i;
  while(ms-->0)
  {
    i=35;
    while(i-->0)
    {
      DelayUs(1);
    }
  }
}
```

```
}  
}  
}
```

RF12 receiver demo:

```
/*****
```

```
    copyright (c) 2006
```

```
Title:          RFM12B transmitter simple example based on PIC C
```

```
Current version: v1.0
```

```
Function:       Package send Demo
```

```
Processor       PIC16F73 DIP-28
```

```
Clock:         10MHz Crystal
```

```
Operate frequency: 434MHz
```

```
Data rate:     4.8kbps
```

```
Package size:  23byte
```

```
Author:        Robben
```

```
Company:       Hope microelectronic Co.,Ltd.
```

```
Contact:       +86-0755-86106557
```

```
E-MAIL:        hopefsk@hoperf.com
```

```
Date:         2006-11-17
```

```
*****/
```

```
#include "pic.h"
```

```
typedef unsigned char uchar;
```

```
typedef unsigned int  uint;
```

```
#define SDI          RB7
```

```
#define SDO          RB6
```

```
#define SCK          RB5
```

```
#define nSEL        RB4
```

```
#define nIRQ        RB3
```

```
#define LED         RA0
```

```
#define LED_OUT()   TRISA0=0
```

```
#define nIRQ_IN()   TRISB3=1
```

```
#define SDI_OUT()   TRISB7=0
```

```
#define SDO_IN()    TRISB6=1
```

```
#define SCK_OUT()   TRISB5=0
```

```
#define nSEL_OUT()  TRISB4=0
```

```
void Init_RF12(void);
```

```
void Write0( void );
```

```
void Write1( void );
```

```
void WriteCMD( uint CMD );
uchar RF12_RDFIFO(void);
void Delayus( uint us );

__CONFIG(0x3FF2);
bank1 uchar RF_RXBUF[19];
void Init_RF12(void)
{

    LED_OUT();
    nSEL_OUT();
    SDI_OUT();
    SDO_IN();
    SCK_OUT();
    nIRQ_IN();
    nSEL=1;
    SDI=1;
    SCK=0;
    SDO=0;
    LED=0;
    WriteCMD(0x80D8); //enable register, 433MHz, 12.5pF
    WriteCMD(0x82D8); //enable receive, !PA
    WriteCMD(0xA640); //
    WriteCMD(0xC647); //
    WriteCMD(0x94A0); //VDI, FAST, 134kHz, 0dBm, -103dBm
    WriteCMD(0xC2AC);
    WriteCMD(0XCC77); //
    WriteCMD(0xCA80);
    WriteCMD(0xCA83); //FIFO8, SYNC,
    WriteCMD(0xC49B);
    WriteCMD(0x9850); //!mp, 9810=30kHz, MAX OUT
    WriteCMD(0xE000); //NOT USE
    WriteCMD(0xC800); //NOT USE
    WriteCMD(0xC000); //1.0MHz, 2.2V
}

void main()
{
    uchar i=0, j=0;
    uint CheckSum;

    Init_RF12();

    while(1)
```



```
SCK=1;
NOP();
}

void Writel( void )
{
    SCK=0;
    NOP();
    SDI=1;
    NOP();
    NOP();
    NOP();
    NOP();
    NOP();
    NOP();
    NOP();
    NOP();
    NOP();
    NOP();
    NOP();
    NOP();
    NOP();
    NOP();
    NOP();
    SCK=1;
    NOP();
}

void WriteCMD( uint CMD )
{
    uchar n=16;
    SCK=0;
    nSEL=0;
    while(n-->0)
    {
        if(CMD&0x8000)
            Writel();
        else
            Write0();
        CMD=CMD<<1;
    }
    SCK=0;
    nSEL=1;
}
```

```
uchar RF12_RDFIFO(void)
{
    uchar i, Result;
    SCK=0;
    SDI=0;
    nSEL=0;
    for(i=0;i<16;i++)
    {
        //skip status bits
        SCK=1;
        NOP();
        NOP();
        SCK=0;
        NOP();
        NOP();
    }
    Result=0;
    for(i=0;i<8;i++)
    {
        //read fifo data byte
        Result=Result<<1;
        if(SDO)
        {
            Result|=1;
        }
        SCK=1;
        NOP();
        NOP();
        SCK=0;
        NOP();
        NOP();
    }
    nSEL=1;
    return(Result);
}

void Delayus( uint us )
{
    uint i;
    while( us-- )
    {
        i=1000;
        while( i-- )
        {
```



```
        NOP();  
    }  
}  
}
```

HOPE MICROELECTRONICS CO.,LTD

Add:4/F, Block B3, East Industrial Area,
Huaqiaocheng, Shenzhen, Guangdong,
China

Tel: 86-755-86096602

Fax: 86-755-86096587

Email: sales@hoperf.com

Website: <http://www.hoperf.com>

<http://www.hoperf.cn>

<http://hoperf.en.alibaba.com>

This document may contain preliminary information and is subject to change by Hope Microelectronics without notice. Hope Microelectronics assumes no responsibility or liability for any use of the information contained herein. Nothing in this document shall operate as an express or implied license or indemnity under the intellectual property rights of Hope Microelectronics or third parties. The products described in this document are not intended for use in implantation or other direct life support applications where malfunction may result in the direct physical harm or injury to persons. NO WARRANTIES OF ANY KIND, INCLUDING, BUT NOT LIMITED TO, THE IMPLIED WARRANTIES OF MECHANABILITY OR FITNESS FOR A PARTICULAR PURPOSE, ARE OFFERED IN THIS DOCUMENT.

©2006, HOPE MICROELECTRONICS CO.,LTD. All rights reserved.